

144/430MHz DUAL BAND YAGI ANTENNA

INSTRUCTION MANUAL

NOTE PLEASE READ ALL INSTRUCTIONS BEFORE ASSEMBLY

FEATURE

1. Dual band for 2m/70cm.
2. Independent element type ensures a nice gain and performance in comparison with Mono band.
3. Stainless steel boom, elements and brackets which ensures superior durability and long performance life in all weather conditions.
4. Light weight, compact and easy to install and re-assemble.

SPECIFICATIONS

Type-----	3-Elements YAGI (145 MHz) 5-Elements YAGI (435 MHz)
Frequency-----	144-146 / 430-440 MHz
Gain-----	9.5dBi / 11.15 dBi
Power input-----	50 watts (FM) max.
Impedance-----	50Ohm
FB ratio-----	more than 12dB
Boom length-----	1,130 mm
Connector-----	SO239
Suitable Mast-----	30 – 55 mm diameter
Weight-----	870 g

ASSEMBLING

1. Identify and arrange the 8-elements and the power feed unit of antenna see color chart.
2. Using flat washer and wing nut join each element and the power feed unit(with Raa and Rab) according to color code to boom.
3. Insert matching rod A & B into power feed unit.
A(longer bar) should be in the hole farthest from the SO239 connector. B(shorter bar) should be in the hole closest to SO239 connector. Using hex.wrench provided, tighten match rods in power feed unit with set screws. Attach shorting bars per diagram.
4. Refer to drawing and attach cable clamp on boom forward from location of U-bolt bracket and on the same side as the power feed unit.
5. Mount antenna on mast in either horizontal or vertically (offset if necessary when using a metal mast – see diagram).
6. Attach coax with PL259 connector to power feed unit and insert coax into clamp. Use electrical tape or wire ties to secure coax along boom.

VSWR ADJUSTMENT

1. Adjust VSWR at center frequency of each band. Move shorting bar further from connector to raise center frequency where VSWR is optimum.
2. Be sure wing nut assembly is tightened on the shorting bar.

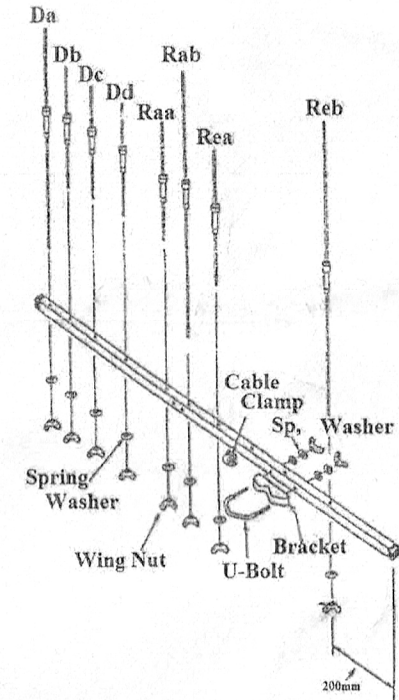
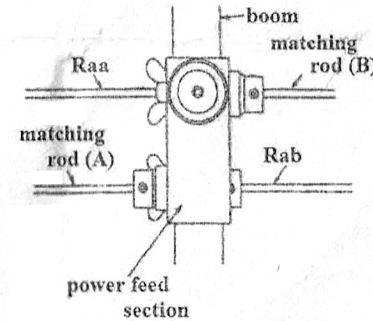
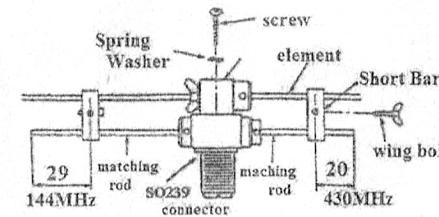

ELEMENTS COLOR CHART

Element (Da)	932mm	– RED
Element (Db)	310	– BLUE
Element (Dc)	312	– YELLOW
Element (Dd)	316	– WHITE
Element (Raa)	330	– BLACK
Element (Rab)	952	– GREEN
Element (Rea)	380	– ORANGE
Element (Reb)	1,044	– BROWN

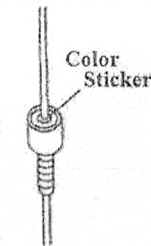

Beam Pattern

